



KOMO®  
Product certificate  
K94620/01



Issued 2019-02-01 Replaces --  
Valid until indefinite D.d. --  
Page 1 of 2

Steel for the reinforcement of concrete B500B: bars  
**EKINCILER DEMİR ve ÇELİK SAN. A.Ş.**

STATEMENT BY KIWA

This product certificate is issued on the basis of BRL 0501 "Steel for the reinforcement of concrete" (Betonstaal)" issued on 1 September 2010, in accordance with the Kiwa-Regulations for Certification.

The quality system and product characteristics in association with Steel for the reinforcement of concrete are assessed periodically.

On this basis Kiwa declares that a justified confidence exists, that the Steel for the reinforcement of concrete delivered by the certificate holder at delivery fulfill:

- the technical specification laid down in this product certificate,
- the product requirements as laid down in this product certificate and in the BRL.

provided that Steel for the reinforcement of concrete has been marked with the KOMO®-mark in a manner as indicated in this product certificate.

Ronald Karel  
Kiwa

*This product certificate is listed in the overview on the website of Stichting KOMO: [www.komo.nl](http://www.komo.nl).  
Advise: consult [www.kiwa.nl](http://www.kiwa.nl) to determine whether this product certificate is valid.*

Kiwa Nederland B.V.  
Sir Winston Churchilllaan 273  
Postbus 70  
2280 AB RIJSWIJK  
Tel. 088 998 44 00  
Fax 088 998 44 20  
[info@kiwa.nl](mailto:info@kiwa.nl)  
[www.kiwa.nl](http://www.kiwa.nl)

Certificate holder  
EKINCILER DEMİR ve ÇELİK SAN. A.Ş.  
Organize Sanayi Bolgesi  
P.K. 240  
31200 Iskenderun - Hatay – Türkiye  
Tel. +90 (326) 656 22 00 (251-258)  
Fax +90(326) 656 22 23



Evaluated is:  
quality system  
product  
Periodic inspection

Steel for the reinforcement of concrete B500B (bars)

**TECHNICAL SPECIFICATION**

**Subject**

Steel for the reinforcement of concrete B500B (bars)

The products are in accordance with the requirements of chapter 4 of guideline BRL 0501 and with that of NEN 6008. The products are meant to be used in constructions of concrete.

**Product characteristics**

Classification : B500B  
 Production method : Hot rolled/water cooled  
 Nominal size : 8 – 10 – 12 – 14 – 16 – 20 – 25 – 28 and 32 mm  
 Delivery condition : bars

**Marking**

The products are marked with a label with upon it at least on a clear and indelible way:

- the KOMO®-logo and the certificate number, figure 1;
- the classification B500B;
- the diameter;
- the rolling mark;
- heatnumber/castnumber/coilnumber;
- name of the certificate holder;
- BRL 0501.

Place of the label: at least one label per bundle of bars.

Steel for the reinforcement of concrete is marked on the following way:

On one rib row by thicken ribs, with the code (9-19), figure 2.

Place of the mark: on a mutual distance of ± 1 meter. The position of the transverse ribs may also be in reverse.



Figure 1

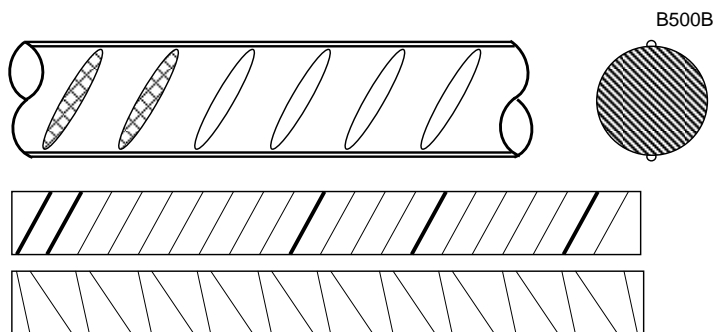

(9-19) Figure 2

**RECOMMENDATIONS FOR CUSTOMERS**

Check at the time of delivery whether:

- the supplier has delivered in accordance with the agreement;
- the mark and the marking method are correct;
- the products show no visible defects as a result of transport etc.

If you should reject a product on the basis of the above, please contact:

- EKINCILER DEMİR ÇELİK SAN. A.Ş.

and, if necessary,

- Kiwa Nederland B.V.

Consult for the proper storage, transport and processing NEN-EN 13670.

**LIST OF DOCUMENTS**

NEN 6008 : Betonstaal  
 NEN-EN 13670 : Het vervaardigen van betonconstructies

\* For the actual version of the standards see the latest version of the BRL 0501 or latest amendment sheet.